



Power Filtering and Resistive Solutions for Elevators and Escalators



ELEVATE YOUR SPACE

TE Connectivity (TE) offers high-performance elevator and escalator solutions to keep people moving. Our expansive lineup of power filtering and resistive components can support your system from design to retrofit. Our customer focused product development, engineering support, and global manufacturing footprint can help make your next-generation elevator and escalator project a success.

Power Filtering and Resistive Solutions for Elevators and Escalators

Custom Solutions and Testing Capabilities

TE's custom capabilities range from modifications of many of our thousands of existing products to unique custom designed solutions to meet application requirements. Our experienced design teams work closely with our customers' engineering personnel, either on-site or remotely, to design advanced products that meet exact system requirements.

Customization can include:

- Mechanical size or mounting
- Specification tolerances
- Wiring and connectorization
- Matched resistance solutions
- Custom windings and foil technology in stamped or etched solutions
- Custom insulations and coatings for a range of ceramic cores in rods, tubes, or flat substrates
- Reduced temperature coefficients
- Overload and adiabatic demands
- Temperature withstand

The customization and development program also includes in-house product testing in our own R&D laboratories.

Test capabilities include:

- Cyclic rated power and overload testing
- Adiabatic (single shot and frequency) testing
- Environmental, mechanical, and repetitive pulse testing
- Conducted EMI in accordance with FCC requirements
- EFT (Electrically Fast Transient) in accordance with European and US Defense standards
- EMI / RFI testing to 30A with insertion loss measured up to 10GHz

Related Literature

Passive Components - Literature No. 1309350

Corcom Product Guide - Literature No. 1654001

Passive Components Resistors - Literature No. 1773442-9

High Current AC Power Line Filters- Literature No. 1773449-2

Resistive Components

Resistors must be carefully chosen to meet specific performance and practical requirements including:

- power rating and density
- accuracy and stability
- short-term overload capacity
- capacitance and inductance
- thermal de-rating and heat dissipation
- electrical isolation
- constrained space and specialized packaging

We work closely with our customers' to design products meeting your exact requirements and can adapt any of our core processes for standard or customer specific requirements.

Adaptable key resistive technologies include:

- Thick film
- Thin film
- Wire-wound
- Foil elements

Precision Resistors

- SMD and leaded components offering high reliability and stability
- Thin film and wire-wound technologies
- Flexibility in MOQ and pack size
- Quick turnaround
(*typical lead time <6 weeks*)
- Accuracy to $\pm 0.01\%$ and 5ppm

Power Resistors

- Power ratings from 1W to > 300kW
- Range of technologies including - wire-wound, thick and thin film, foil, carbon and ceramic composition
- In-house design and test facilities for development of specification driven products
- Customization capabilities of standard products
- Supported by wide range of commodity power / low ohmic resistors

EMI / RFI Power Line Filters

Our experienced team works closely with our customers to help bring equipment into compliance with strict emissions standards. TE's Corcom EMI & RFI filters offer solutions for:

- Incoming power filtering
- Signal and control line filtering
- Board level filtering for control systems
- DC power filtering for control cabinets
- A broad range of off-the-shelf product
- Custom designed solutions for unique applications

We can adapt any of our products for specific requirements and offer:

- Superior materials and workmanship
- Highly experienced engineering staff
- Application and design consultation
- Testing and qualification assistance
- Customized electrical and mechanical solutions

Single Phase Power Filters

- Over 40 unique series of power line products
- Current rating up to 60A
- Voltage ratings up to 250V
- Various termination options:
 - Standard receptacle (IEC)
 - Quick connect
 - Stud termination
- UL, CSA and VDE approved products available

Three Phase / High Current Power Filters

- Broad range of three phase power line products
- Current rating up to 400A
- Voltage ratings 270/480V and 250/440V
- Various termination options:
 - Stud termination
 - Terminal block
- Versions available for Delta and/or WYE wiring
- UL, CSA and VDE approved products available

Elevator and Escalator Application Guide

Elevator Systems

1 Incoming Power

- Balancing Resistors
BDS, MPT, HH / HJ, RGP
- Three Phase EMI / RFI Power Filters
A, ADT, AYA, AYC, BCF, CFN, FCD Series

2 Control System *(Schematic on Page 5)*

- Current Sense Resistors
OS, RL73, SBL, SL, SM, TLR / HL
- Capacitor Pre-charge / Discharge Resistors
C / ER, HS / THS, SM, SQ, TT / TK, YP
- Precision Resistors
HOLCO, RN73 / RP73 / CPF
- Power Resistors
CBT / CCR, MPC, MPR, MPT, RR / ROX, SBC
- High Voltage Resistors
HH / HJ, RGP
- Single Phase EMI / RFI Power Filters
EMC, FC, K, S, SB, SK Series

3 Drive and Brake System

- Braking Resistors
CFH, CJS, HS / THS, LOAD BANK, R5000
- Snubber Resistors
BDF, BDS, R5000
- Capacitor Pre-charge / Discharge Resistors
C / ER, HS / THS, RR / ROX, SBC, SM, SQ, TT / TK, YP
- Inrush Limiting Resistors
CFH, HS / THS, MRF, TT / TK

4 Door Motor

- Braking Resistors
CFH, CJS, HS / THS, LOAD BANK, R5000, SQ, TT / TK

5 Car Control Board

- Current Sense Resistors
RL73, SL, SM, TLR / HL
- Capacitor Pre-charge / Discharge Resistors
C / ER, HS / THS, RR / ROX, SBC, SM, SQ
- Precision Resistors
HOLCO, RN73, RP73, CPF
- Power Resistors
CBT / CCR, MPC, MPR, MPT

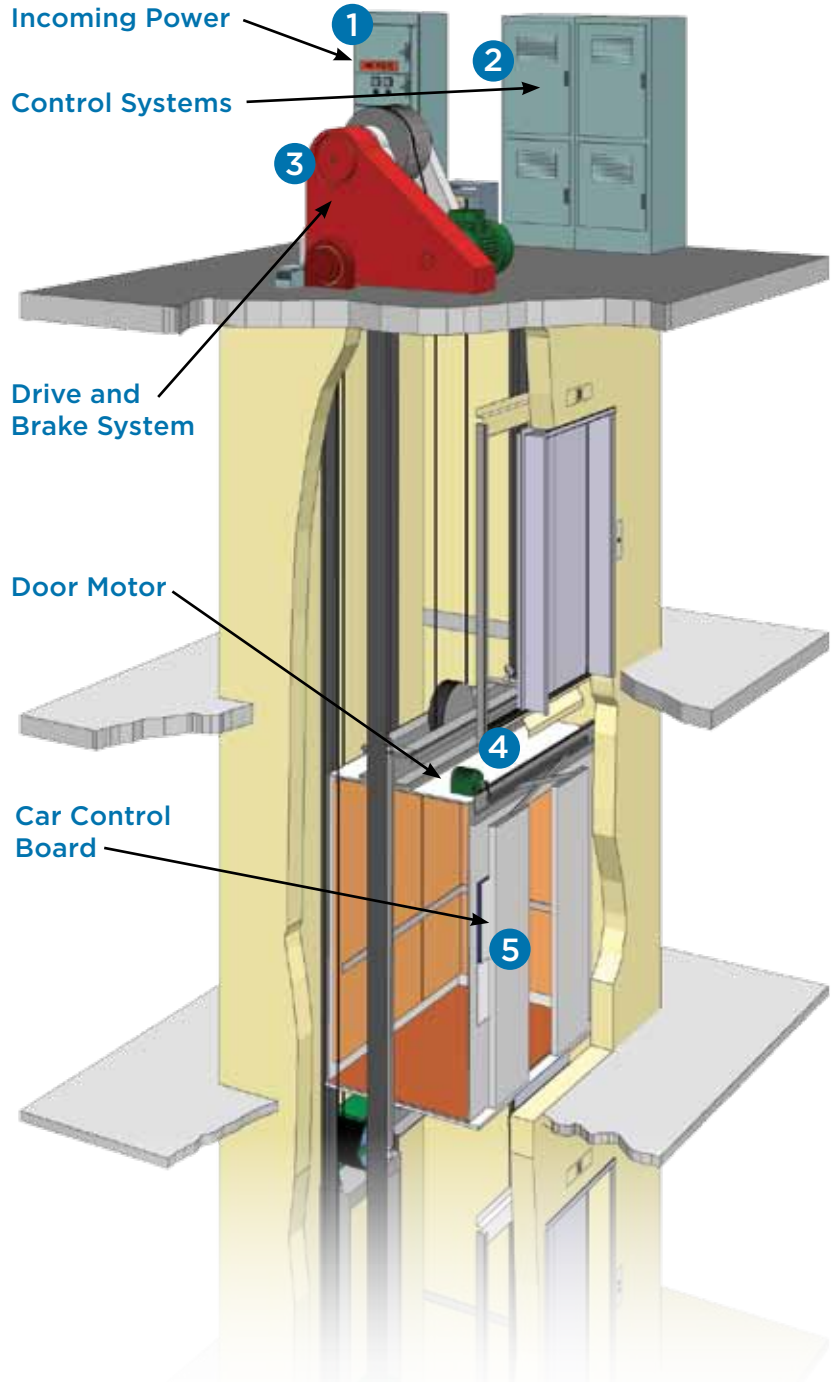

Escalator Systems

1 Incoming Power

- Balancing Resistors
BDS, MPT, HH / HJ, RGP
- Three Phase EMI / RFI Power Filters
A, ADT, AYA, AYC, BCF, CFN, FCD Series

2 Control System *(Schematic on Page 6)*

- Current Sense Resistors
OS, RL73, SBL, SL, SM, TLR / HL
- Capacitor Pre-charge / Discharge Resistors
C / ER, HS / THS, SM, SQ, TT / TK, YP
- Precision Resistors
HOLCO, RN73 / RP73 / CPF
- Power Resistors
CBT / CCR, MPC, MPR, MPT, RR / ROX, SBC
- High Voltage Resistors
HH / HJ, RGP
- Single Phase EMI / RFI Power Filters
EMC, FC, K, S, SB, SK Series

3 Drive and Brake System

- Braking Resistors
CFH, CJS, HS / THS, LOAD BANK, R5000
- Snubber Resistors
BDF, BDS, R5000
- Capacitor Pre-charge / Discharge Resistors
C / ER, HS / THS, RR / ROX, SBC, SM, SQ, TT / TK, YP

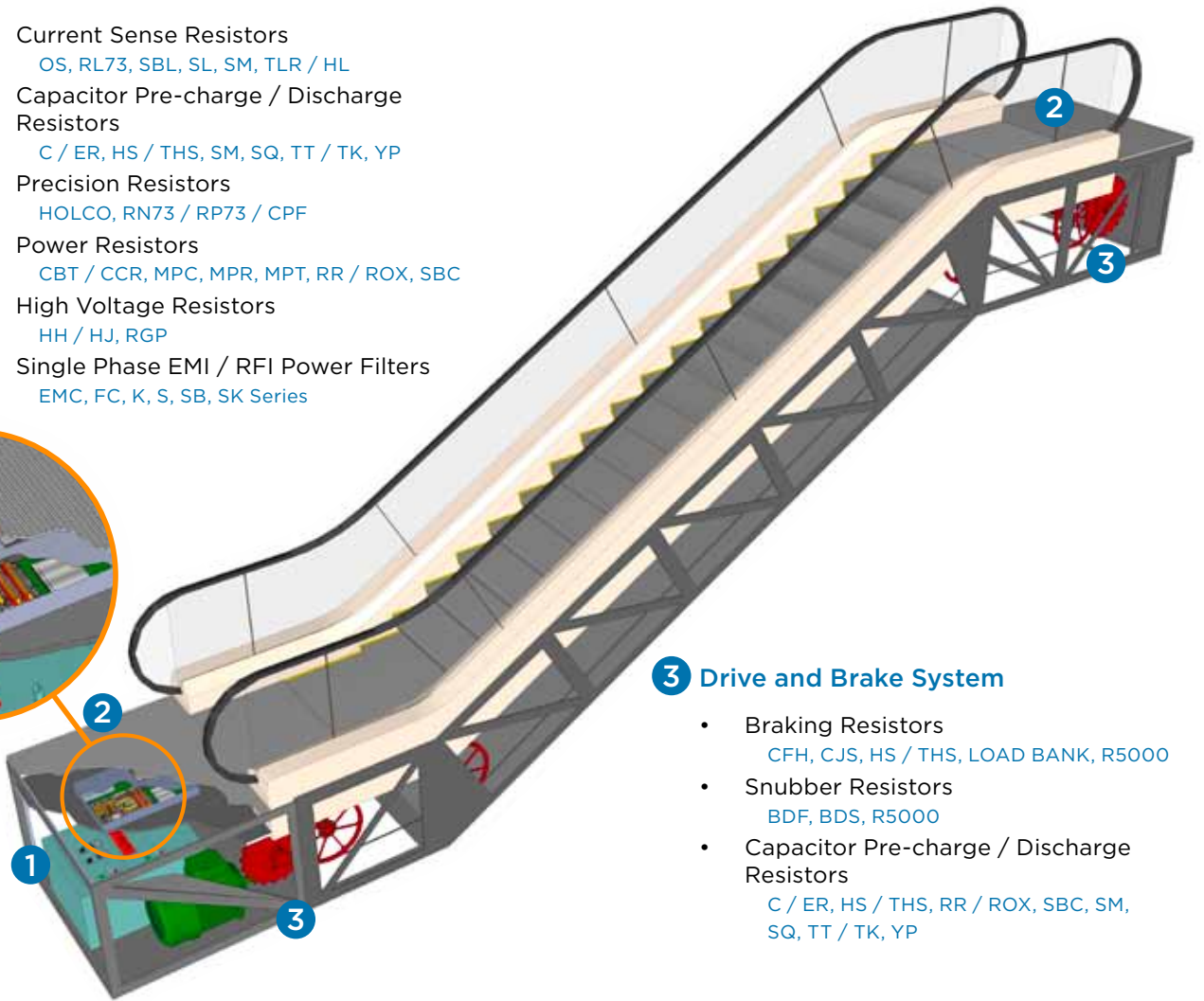

Foil & Wirewound Technology



Thick Film Technology



Single Phase RFI Filters



3-Phase RFI Filters

Elevator and Escalator Drive Circuits

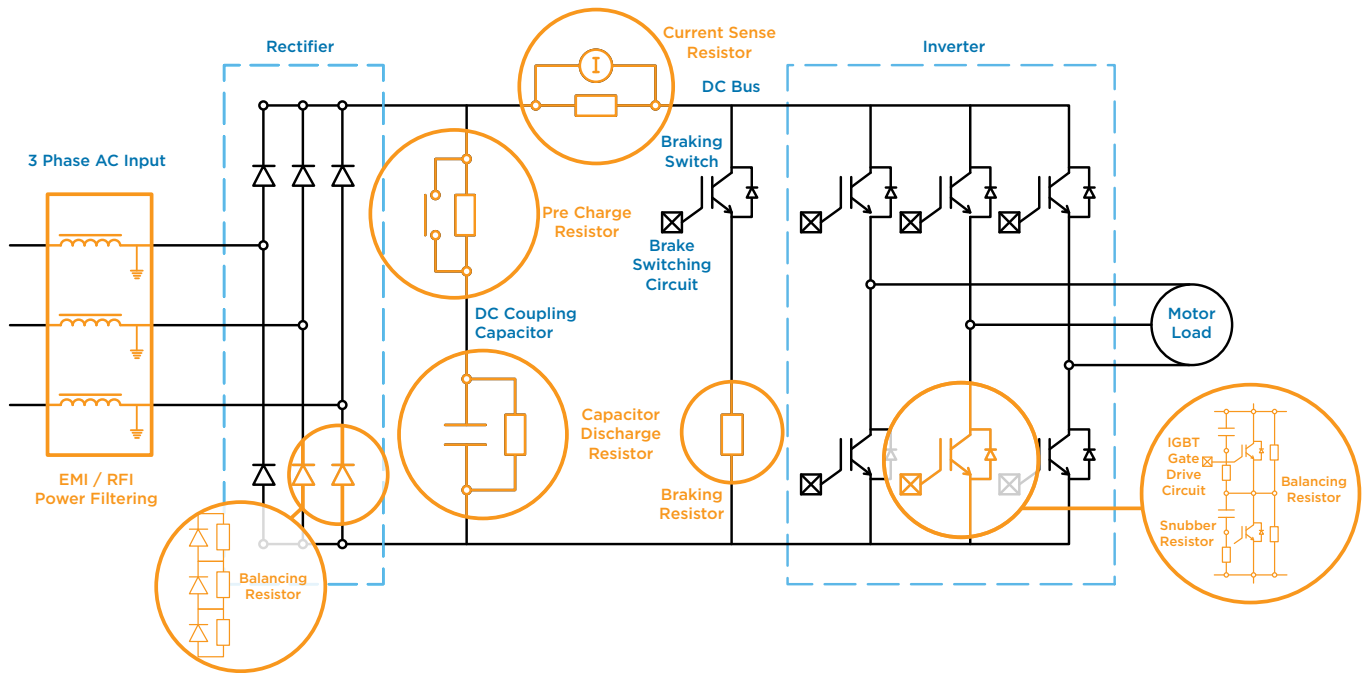

Pre-Charge Resistor

This is used on system start up to charge the DC coupling capacitor. The resistor limits the inrush current during charging of the DC coupling capacitor. This capacitor sits across the DC voltage source to keep the line voltage constant when the input voltage drops low. The resistor must be able to absorb high energy from a single pulse, over a short time.

Capacitor Discharge Resistor

The resistor is fitted across the capacitor terminals to provide a safety function. When the voltage to the capacitor is removed, the resistor discharges any residual voltage in the capacitor making it safe to touch. The resistor must handle continuous power as long as it is connected to a voltage source.

Braking Resistor

The resistor is used in a variable speed drive to absorb the energy created when the motor decelerates quickly. These can be fitted internally or externally to the drive. The rate that the motor decelerates is controlled by the amount of energy dumped into the resistor. During the braking cycle (deceleration) lots of little pulses of energy are dissipated by the resistor over a short period of time.

Balancing Resistor

The resistor is used to balance the voltage across critical components (such as IGBTs) when they are connected in series. This is to ensure that each component has equal voltage stress during operation.

Current Sense Resistor

A low ohmic resistor creates a small voltage drop in the circuit. As the current in the circuit changes the voltage drop will vary. The change in voltage drop is used to measure the current to or from the circuit. This current can be monitored allowing an action in the control software.

Snubber Resistor

The resistor is used to absorb transient high voltage spikes produced by switching a solid state switch (like relays, IGBTs, GTOs, etc.). It is connected in series with a capacitor across the switch. These switching operations can be very high frequency therefore the resistor must have a low inductance, so that the transient spike is not transferred back into the switch.

RFI / EMI Power Filters

Filters are an integral part of EMC design of a product. They are used to attenuate conducted noise leaving the system and lower susceptibility of the equipment to incoming power line noise. RFI is conducted through a power line in two modes: asymmetric (common mode) line to ground or symmetric (differential mode) line to line.

Product Application Guide

Passive Components								
Family	Technology	Key Features	Control Circuitry	Capacitor Precharge/Discharge	Braking	Balancing	Snubber	Current Sense
BDF	Foil	400W Isotop					•	
BDS	Thick Film	100 to 600W Isotop				•	•	
C / ER	Wirewound	2.5 to 14W, C=Vitreous / ER=Silicone	•	•		•		
CBT/CCR	Carbon/Ceramic	1/4 to 2W Pulse Withstand	•					
CFH	Wirewound	350 to 2200W Aluminium Housed			•			
CJS	Wirewound	175 to 1000W Mineral Filled			•			
HH/HJ	Thick Film	High Voltage	•			•		
HOLCO	Thin Film	0.25 to 1W Precision					•	
HS/THS	Wirewound	5W to 300W Aluminium Housed	•	•	•			
LOAD BANK	Wirewound	Customized Load Bank			•			
MRF	Wirewound	300 to 1300W Low Profile						
MPC	Thick Film	3 to 10W Planar	•				•	
MPR	Thin Film	20W to 220 Radial	•			•	•	
MPT	Thick Film	20W to 100W Radial	•			•	•	
OS	Foil	Low Ohm Shunt	•					•
R5000	Wirewound/Foil	250W Low Profile			•		•	
RGP	Thick Film	0.25W High Ohmic	•			•	•	
RL73	Thick Film	SMD Current Sense	•					•
RN73 / RP73 / CPF	Thin Film	SMD Precision Chip	•				•	
RR/ROX	Metal Film/Oxide	1 to 7W High Power	•	•		•	•	
SBC	Wirewound	4 to 40W Ceramic Cased	•	•				
SL / SBL	Foil	0.25W to 2.5W Current Sense	•					•
SM	Wirewound/Oxide	1 to 5W Moulded Power Chip	•	•				•
SQ	Wirewound/Oxide	2 to 40W Ceramic Cased	•	•	•			
TLR/HL	Foil	0.5 to 3W Current Sense	•				•	•
TT/TK	Wirewound	10 to 2500W Tubular		•				
YP	Wirewound	8 to 10W Capacitor Discharge		•		•		

EMI / RFI Power Line Filters				
Series	Type	Rated Current / Voltage (max.)	Agency Approvals	
EMC Series	Single Phase	Compact Dual Stage RFI Filter	30A / 250 VAC	UL, CSA, VDE
FC Series		RFI Filter for Frequency Converters	36A / 250 VAC	UL
K Series		General Purpose RFI Filter	30 to 60A / 250 VAC	UL, CSA, VDE
S Series		Multipurpose RFI Filter for Emission Control	60A / 250 VAC	UL, CSA, VDE
SB Series		High Performance / High Impedance RFI Filter	30A / 250 VAC	UL, CSA, VDE
SK Series		High Performance Filter for SMPS Emission Control	30 to 40A / 250 VAC	UL, CSA, VDE
A Series	3-Phase	High Performance RFI Filters for WYE or Delta Applications	30 to 60A / 440 VAC / 250 VAC	UL, CSA, VDE
ADT Series		High Performance High Current Delta RFI Filter	32 to 200A / 480 VAC / 277 VAC	UL
AYA Series		WYE or Delta RFI Power Line Filter	26 to 50A / 440 VAC / 250 VAC	UL
AYC Series		WYE or Delta RFI Power Line Filter	36 to 180A / 480 VAC / 277 VAC	UL
BCF Series		Compact Delta RFI Filter for Universal Applications	30 to 180A / 480 VAC / 277 VAC	UL, CSA, VDE
CFN Series		Delta Power Line Filter for High Voltage Applications	300 to 600A / 480 VAC / 277 VAC	UL
FCD Series		Delta External Filter for Frequency Converters	36 to 230A / 480 VAC / 277 VAC	UL

FOR MORE INFORMATION

te.com/industry/commercial-building-technology

te.com/passives

corcom.com

Technical and Product Support

Internet:	te.com/help
Austria:	+43 1 90560 1228
Canada:	+1 905 475 6222
China:	+86 400 820 6015
France:	+33 1 3420 8686
Germany:	+49 6251 133 1999
Italy:	+39 011 4012 632
Mexico:	+52 55 1106 0800
Nordic:	+358 9 5123 4218
Latin/South America:	+54 11 4733 2200
Spain/Portugal:	+34 93 291 0366
Switzerland:	+41 71 447 04 47
United Kingdom:	+44 800 267 666
United States:	+1 800 522 6752

Part numbers in this brochure are RoHS Compliant*, unless marked otherwise.

*as defined te.com/leadfree

te.com

© 2011 Tyco Electronics Corporation, a TE Connectivity Ltd. company. All Rights Reserved.

8-1773459-4 CIS JG 04/2011

Corcom, TE Connectivity, TE connectivity (logo) and TE (logo) are trademarks of the TE Connectivity Ltd. family of companies. Other logos, product and Company names mentioned herein may be trademarks of their respective owners.

While TE has made every reasonable effort to ensure the accuracy of the information in this brochure, TE does not guarantee that it is error-free, nor does TE make any other representation, warranty or guarantee that the information is accurate, correct, reliable or current. TE reserves the right to make any adjustments to the information contained herein at any time without notice. TE expressly disclaims all implied warranties regarding the information contained herein, including, but not limited to, any implied warranties of merchantability or fitness for a particular purpose. The dimensions in this catalog are for reference purposes only and are subject to change without notice. Specifications are subject to change without notice. Consult TE for the latest dimensions and design specifications.

